

料号 material No.	品名 Parts Name	型号 Part NO.	螺纹口直径 screw dia. d2ø		Dimensions (mm)					美制螺栓号 USA screw
40-RNBL1.25-5	圆形裸端头 (T0型)	RNBL1.25-5	5.3	9.8	18.0	8.5	4.8	3.4	1.7	#10
				B	L±1.5	F	E	DΦ	dΦ	

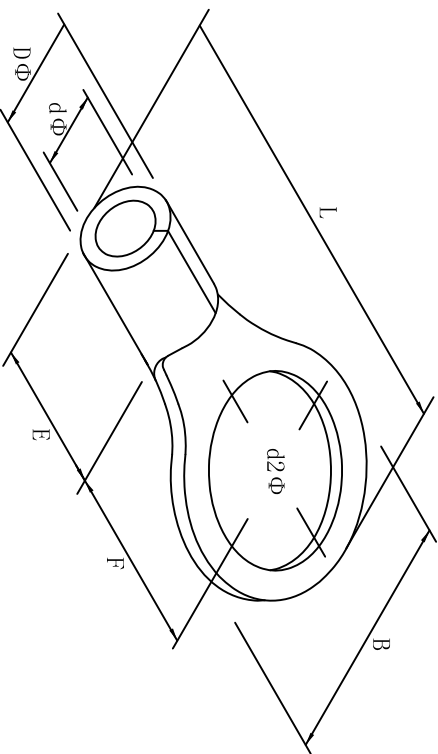

导线截面 0.5-1.5mm² (美国线规22-16)
 最大电流: I_{max}=19A
 材质: 紫铜
 材料厚度: 0.75mm



DIMENSION	TOLERANCES									DWG. BY	UNIT	
0.0 0.00	±0.5									<i>Lin Liang</i>	mm	
FRIST ANGLE PROJ		A	NEW PART	<i>oullivan</i>	<i>3%</i>	<i>wang</i>	<i>202105</i>	APP. BY	<i>wang zhiqian</i>	DWG. NO.	HIWA/QR-JZ-40-RNBL1.25-5	
			REVISION RECORD					CHK. BY	<i>oullivan</i>	REV.	A	

未经许可不得修改和复印
 该知识产权属于技术质量部