

料号 material No.	品名 Parts Name	型号 Part NO.	螺钉口直径 screw dia. d2ø	Dimensions (mm)					美制螺栓号 USA screw
40-RNBSS3.5-5	圆形裸端头 (T0型)	RNBSS3.5-5	5.3	B	L±1.5	F	E	DΦ	dΦ
				8.0	18.0	7.7	6.0	5.0	3.0
									#10

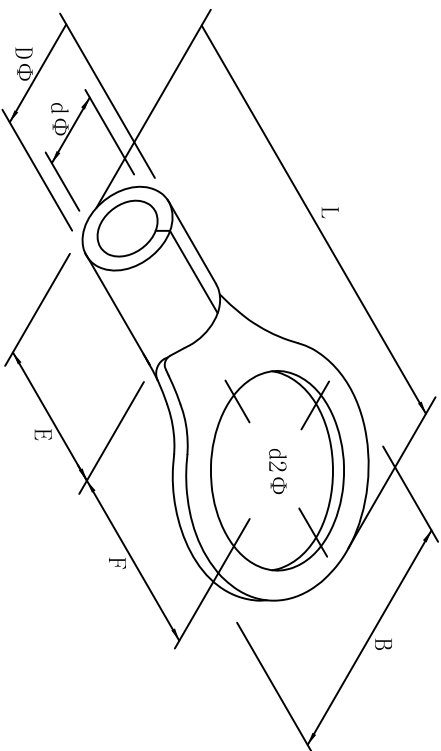

导线截面 2.5-4mm² (美国线规14-12)
 大电流: I_{max}=37A
 材质: 紫铜
 材料厚度: 1.0mm



DIMENSION	TOLERANCES							DWG. BY	UNIT	
0.0 0.00	±0.5							<i>liu liang</i>	mm	
FRIST ANGLE PROJ		A	NEW PART	<i>oullivan</i>	<i>3% wang</i>	<i>2021/05</i>	APP. BY	<i>wang zhiqian</i>	DWG. NO.	HIMA/QR-JZ-40-RNBSS3.5-5
			REVISION RECORD				CHK. BY	<i>oullivan</i>	REV.	A

未经许可不得修改和复印
 该知识产权属于技术质量部