

料号 material No.	品名 Parts Name	型号 Part NO.	螺钉口直径 Screw dia. d2 \varnothing	Dimensions(mm)			导线截面 Cable size (mm ²)
40-SC300-16	窥口铜接线端子	SC300-16	17.0	d \varnothing	D \varnothing	L1	L
			24.0	30.0	44.0	100.0	300

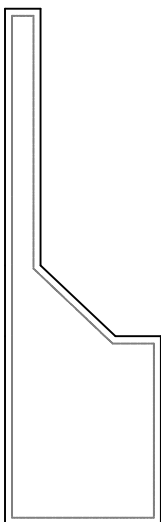

材质：紫铜
表面处理：镀锡

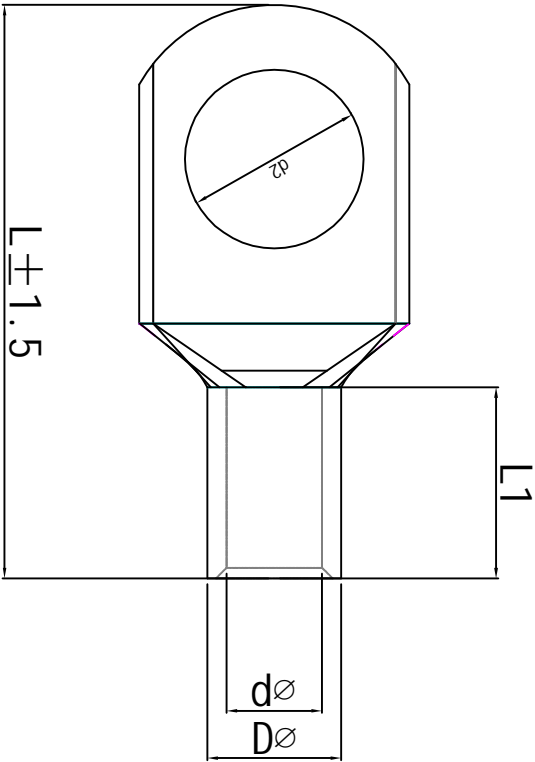

未经授权不得修改和复印
该知识产权属于技术质量部

DIMENSION		TOLERANCES		NEW PART		REVISION RECORD		DWG. BY	UNIT	mm
0.0								liu liang		
0.00		±0.5						sullivan	REV.	A
FIRST ANGLE PROJ		A						wang zhiyan	DWG. NO.	H1W/A/DR-JZ-40-SC-300-16

HIMA 苏州惠华电子科技有限公司